

# Fuel Conditioning Series

## FCS-5050

Today's modern diesel engines, more than ever, require clean and dry fuel to run smoothly and reliably. High- pressure injectors and close tolerance components leave little toleration for contaminated fuels. The Kaydon Filtration Fuel Conditioning Series of products gives you the assurance that the diesel fuels you are using in your diesel engine applications are clean, water-free, and exceed the latest ASTM D975 Diesel Fuel Specification<sup>(1)</sup>.

Contamination begins from the moment diesel fuel leaves the refinery and begins its journey to your location. Dirt, water, biological elements, and other debris finds its way into the fuel as it is transported and stored. If unchecked, this contamination can lead to excessive wear, down-time, or even damage to your expensive, diesel powered equipment.

In industrial applications like mining, construction, marine, or anywhere diesel fuel is transferred or stored, the FCS-5050 removes water and particulates from your diesel fuel. Placed in series with your fuel flow line, the FCS-5050's multi-stage conditioning process removes dirt, debris, water, and performs a final polishing before the fuel is dispensed to your diesel engine application or transferred to your storage tank.

### Specifications & Details

System flow	up to 50 gpm (190 LPM)
System pressure	Maximum Allowable Working Pressure: 150 psig (10.34 BAR)
Electrical	Not applicable, unless optional water sump heater is installed (see OPTIONS section)
Materials of construction	Pressure Vessels: Carbon Steel and Cast Iron Piping: Carbon Steel Valves, Tubing and Gauges: Stainless Steel, Bronze and Brass
Inlet/Outlet connections	2" ANSI B16.5 Flanged Connections
Fluid compatibility	#2 Diesel
Fuel cleanliness	Particulate: ISO Cleanliness Code 16/14/12 <sup>(2)</sup> Water: Removal to less than 500 ppm <sup>(3)</sup>
All weather construction	Epoxy coated vessels
Weight	1,400 lbs (635 Kgs) approximate
Dimensions	100" L x 40" W x 51" H (2540 mm x 1016 mm x 1295 mm)



### Features and benefits

- **SAMPLE PORTS (input/output):** Allow for pre and post conditioning sampling of fuels during system operation for test and analysis.
- **ISOLATION VALVES:** Allow for convenient way to isolate the system for filter changes.
- **PRE-FILTER STAGE:** The first step in the conditioning process. This stage removes damaging dirt and debris before the fuel is passed to the Coalescer/Separator stage for water removal and polishing.
- **COALESCER/SEPARATOR STAGE:** At this stage, water in the fuel is removed to provide drier fuel to protect internal engine components and prevent water-related fuel issues, plus providing final polishing for particulate removal.
- **DIFFERENTIAL PRESSURE GAUGES:** Monitoring the pressure across each filtration vessel, these gauges are your first indicator that the filters have reached a point where they need to be replaced.
- **WATER METER:** Located in the water drain, this meter measures and records the total water that has been removed from the fuel processed by the system.
- **SKID MOUNTING:** Conveniently designed on a single skid, with forklift points for accessible system positioning, drip containment rim, skid drain port and mounting tabs.
- **SIGHT GLASS :** Provides initial visual indication of the accumulation of water in the coalescer vessel.



## Features and benefits options

- **DYNAMIC CONTROL VALVE (OPTIONAL):** – DCV (optional): This automatic flow control valve responds to conditions that may impact the quality of the fuel conditioning process. If water content is detected in the fuel that is larger than the system’s ability to remove it, the DCV slows or stops the fuel flow until the system disposes of the excess water. Additionally, the valve can detect high differential pressure caused by clogged filter elements. This condition will also cause the DCV to interrupt system fuel flow until the situation has been corrected.
- **SUMP HEATER (OPTIONAL):** When the Fuel Conditioning System is used in cold weather climates, the Sump Heater will prevent freezing of any water accumulated in the water sump of the Coalescer Vessel.
- **EXPORT CRATING (OPTIONAL):** Heavy duty and rugged crate for extra protection or overseas shipments.

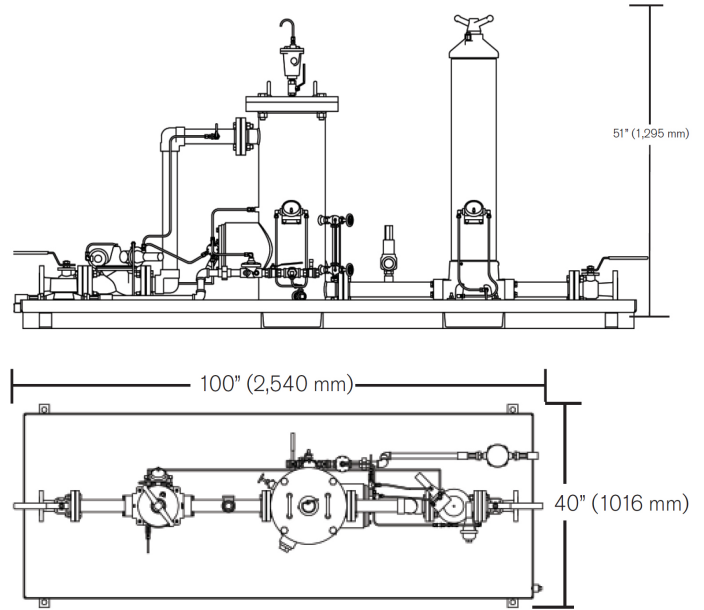

## Options

DESCRIPTION	PART NUMBER
Dynamic Control Valve (adds 200 Lbs (90 KG))	D994011
110 VAC Sump Heater 1KW 110V/1PH/60HZ	A400036-110
220 VAC Sump Heater	A400036-220
Export Crating	B604438-EXPORT

## Consumables

MODEL / DESCRIPTION	QTY	PART NUMBER
Pre-filter elements <sup>(4)</sup>	1	A910118
Coalescer elements	3	A910134
Separator elements	3	608061
Pre-filter Lid Seal <sup>(5)</sup>	1	54M99V
Coalescer/Separator Lid seal <sup>(5)</sup>	1	A900322

### Footnotes

(1) Limit = 0.050 maximum water and sediment, units = % volume (free and emulsified water only) - Test Method ASTM D 2709: Water and Sediment in Middle Distillate Fuels by Centrifuge

(2) As measured with inline automatic particle monitor calibrated to ISO 11171 and influent fuel no greater than ISO Cleanliness Code 22/19/17

(3) Total Water content (free, emulsified and dissolved) as measured by ASTM D6304-04 (Karl Fischer method)

(4) Removes 99.9% of all particles 4 micron and larger per ISO 16889

(5) Required for element changes.

